

Product Specification Sheet for:
Pendulum Swing with Nest Basket 904622150R



Compliant to EN1176

Product Name	Pendulum Swing with Nest Basket
Product Code	904622150R
Material	BS EN 350-02 Class 1 Robinia Timber
Product Category	FHS Moving Equipment
Age Range	8 to 14
Fixings	Stainless Steel Fixings & Galvanised Plates
Free Space Area m2	58
Free Space Loosefill m2	73
FFH	2.40
Area Required (LxW)	8.8 (Dia) or 9.8 (Dia)
Grassmat Total (M ²)	74
Edge Length LM	27

Plan View
 Not to scale

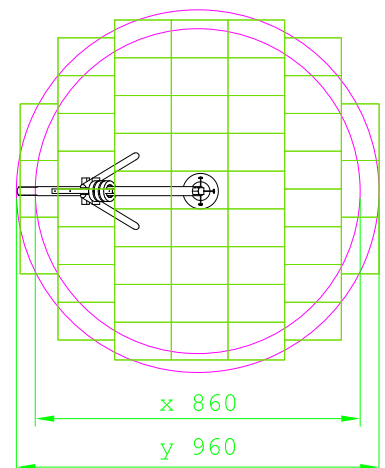
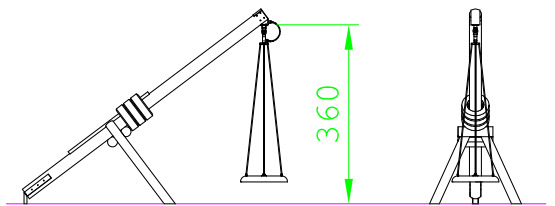

Product Description

The pendulum swing is a very popular piece of equipment as it is suitable for lots of children. The swing helps users to develop a sense of rhythm, movement and manual strength. It also provides a social gathering place, particularly as a tyre swing.



Company No. SC200761
 © Jupiter Play & Leisure Ltd. 2014.

www.jupiterplay.co.uk
info@jupiterplay.co.uk

HEAD OFFICE: 0131 445 7989
 SOUTHERN OFFICE: 0115 969 9859