

Product Name	Tortoise Springer
Product Code	90840115RO
Material	BS EN 350-02 Class 1 Robinia Timber
Product Category	FHS Equipment for Small Children Springer
Age Range	2 to 6
Product Type	Moving Springer
Fixings	Stainless Steel Fixings & Galvanised Plates
Free Space Area m2	11.80
Free Space Loosefill m2	11.80
FFH	1.00
Area Required (LxW)	4 x 3.5
Grassmat Total (M ²)	6

Plan View
 Not to scale

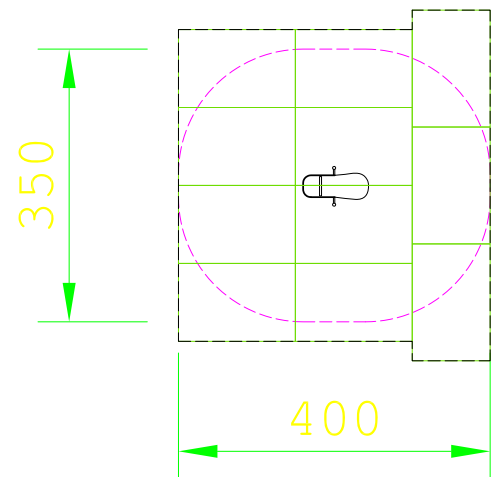

Product Description

The Tortoise Springer is designed for children aged 2-6 years. The design of our springers is based on creatures and items that young children can identify with such as animals. Our range of springers encourage children's imagination and allow them to experience a range of movement.



Compliant to EN1176



Company No. SC200761
 © Jupiter Play & Leisure Ltd. 2014.

www.jupiterplay.co.uk
info@jupiterplay.co.uk

HEAD OFFICE: 0131 445 7989
 SOUTHERN OFFICE: 0115 969 9859